

SPRUE BUSHES

SPRUE BUSH "B1/B1T" / 511
 SPRUE BUSH "B3/B3T" / 512
 SPRUE BUSH "B4/B4T" / 513
 SPRUE BUSH "B5" / 514
 SPRUE BUSH "B6" / 515
 SPRUE BUSH "B7" / 516
 SPRUE BUSH "B8" / 517
 SPRUE BUSH "B11/B11T" / 518
 SPRUE BUSH "B31/B31T" / 519

V/24
 V/25
 V/26
 V/27
 V/28
 V/29
 V/30
 V/31
 V/32

COOLING ELEMENTS

COOLING CIRCUIT PLUG / 522
 COOLING CIRCUIT SCREW PLUG / 509
 MALE/FEMALE COOLING PIPE / 510
 QUICK RELEASE COUPLING (SOCKET) / 501
 QUICK RELEASE COUPLING WITH VALVE (SOCKET) / 502
 90° QUICK RELEASE COUPLING / 503
 SEAL FOR QUICK RELEASE COUPLER / 521
 FEMALE HOSE NIPPLE (HEXAGON TYPE) / 508
 MALE HOSE NIPPLE (HEXAGON TYPE) / 507
 FEMALE JOINT PLUG / 506
 MALE JOINT PLUG / 505
 O-RING / 520

V/23
 V/22
 V/ 9
 V/ 1
 V/ 2
 V/ 3
 V/34
 V/ 8
 V/ 7
 V/ 6
 V/ 5
 V/33

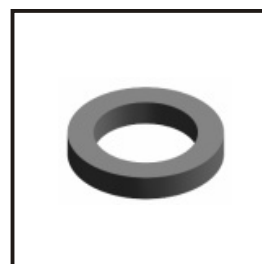

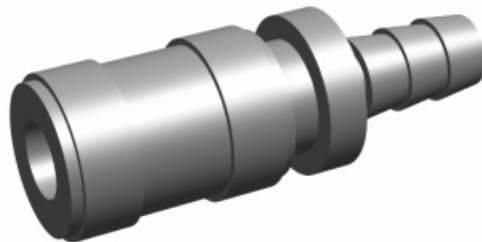
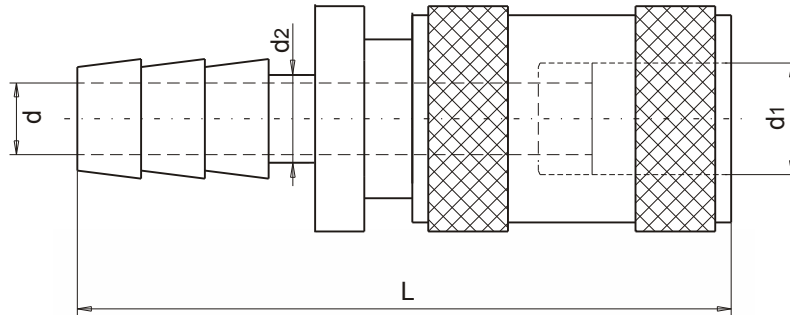
ENCHUFE RAPIDO
QUICK RELEASE COUPLING (SOCKET)
501

MATERIAL : Latón / Brass

d	Medidas del adaptador			L
	d1	R	d2	
6	9	1/4" gas - 1/8" gas	9	57
8	13	1/4" gas - 3/8" gas	11	72

FORMA DE PEDIDO / ORDER FORM : d.

ENCHUFE RAPIDO CON VALVULA

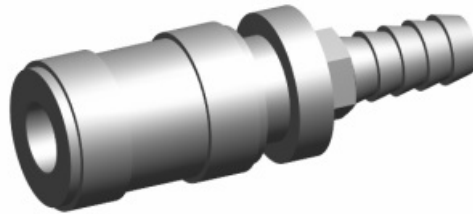
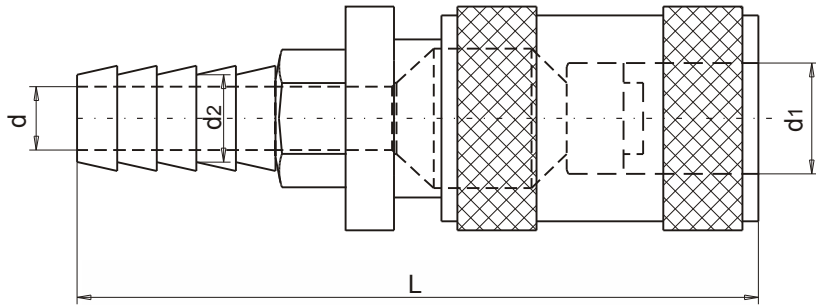
QUICK RELEASE COUPLING WITH VALVE (SOCKET)



MATERIAL : Latón / Brass

d	Medidas del adaptador Connector plugs		d2	L
	d1	R		
6	9	1/4" gas - 1/8" gas	9	70
8	13	1/4" gas - 3/8" gas	11	85

FORMA DE PEDIDO / ORDER FORM : d.

ENCHUFE RAPIDO ACODADO
90° QUICK RELEASE COUPLING

503

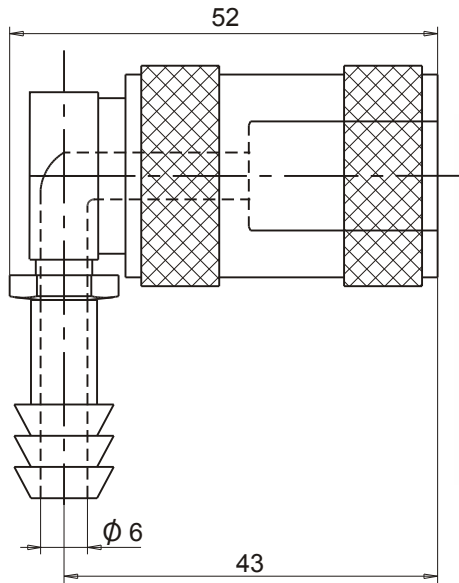

MATERIAL : Latón / Brass

FORMA DE PEDIDO : Enchufe rápido acodado.

ORDER FORM : 90° Quick release coupling

90° QUICK RELEASE COUPLING WITH VALVE

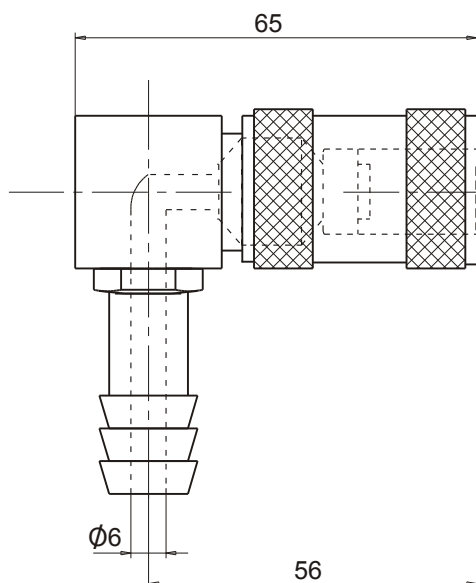

MATERIAL : Latón / Brass

FORMA DE PEDIDO : Enchufe rápido acodado con válvula.

ORDER FORM : 90° Quick release coupling with valve

ADAPTADOR PARA ENCHUFE RAPIDO MACHO
MALE JOINT PLUG

505

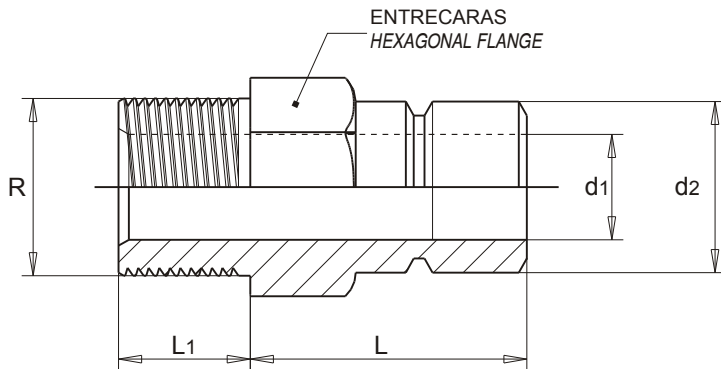

MATERIAL: Latón / Brass

R	d1	d2	Entrecaras Hexagon flat distance	L	L1
1/8"	6	9	13	15	10
1/4"	6	9	13	15	10
1/4"	8	13	17	21	10
3/8"	8	13	17	21	10

FORMA DE PEDIDO / ORDER FORM : R x d1

FEMALE JOINT PLUG

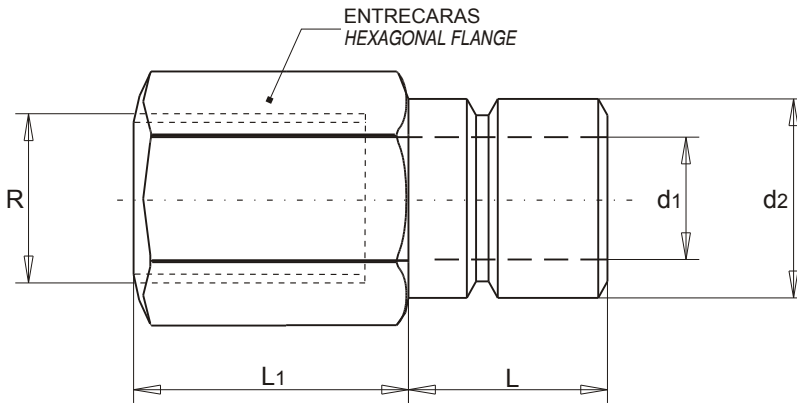

MATERIAL: Latón / Brass

R	d1	d2	Entrecaras Hexagon flat distance	L	L1
1/8"	6	9	13	10	15
1/4"	6	9	17	10	15
1/4"	8	13	17	15	15
3/8"	8	13	17	15	15

FORMA DE PEDIDO / ORDER FORM: R x d1

BOQUILLA REFRIGERACION MACHO
MALE HOSE NIPPLE (HEXAGON TYPE)

507

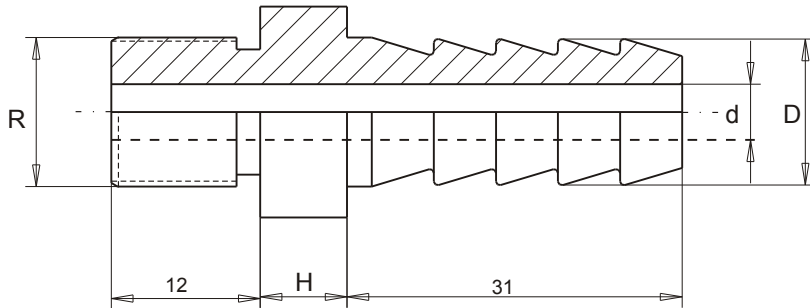

MATERIAL: Hierro o Latón / *Steel or Brass*

R	D	d	Entrecaras <i>Hexagon flat distance</i>	H
1/8"	13	6	14	7
1/4"	13	7	14	7
1/4"	15	7	17	10
3/8"	15	9	17	10

FORMA DE PEDIDO / ORDER FORM: R / Material

FEMALE HOSE NIPPLES (HEXAGON TYPE)

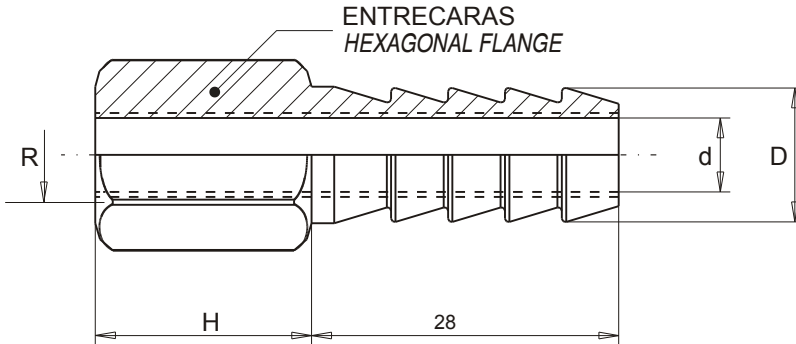

MATERIAL: Latón / Brass

R	D	d	Entrecaras Hexagon flat distance	H
1/8"	13	7	14	15
1/4"	13	7	16	15
3/8"	15	10	20	20
3/8"	15	9	20	20

FORMA DE PEDIDO / ORDER FORM : R

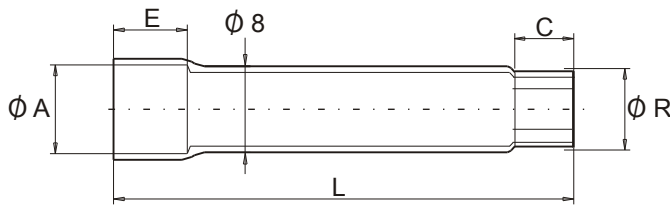
TUBO ROSCADO MACHO / HEMBRA
MALE / FEMALE COOLING PIPE
510

TUBO ROSCADO HEMBRA / FEMALE COOLING PIPE
MATERIAL : Hierro zincado / *Zinc plated steel*

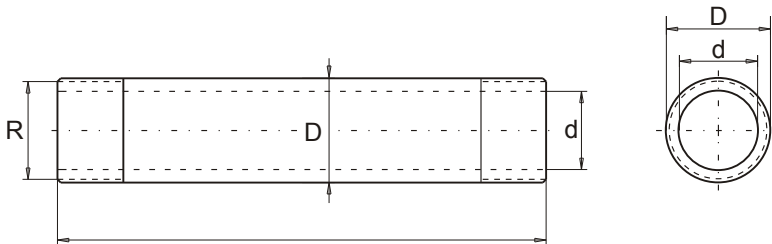
A	B	C	D	E	R	L				
						50	75	100	125	150
1/8"	10	9	5	11	1/8"	*	*	*	*	*
1/4"	14	10	8	12	1/4"	*	*	*	*	*

FORMA DE PEDIDO / ORDER FORM: R x L.

TUBO ROSCADO MACHO / MALE COOLING PIPE
MATERIAL : Hierro zincado / *Zinc plated steel.*

R	d	D	L							
			50	75	100	125	150	200	250	300
1/8"	7	10	*	*	*	*	*	*	*	*
1/4"	9	13	*	*	*	*	*	*	*	*
3/8"	12	16	*	*	*	*	*	*	*	*

FORMA DE PEDIDO / ORDER FORM: R x L.

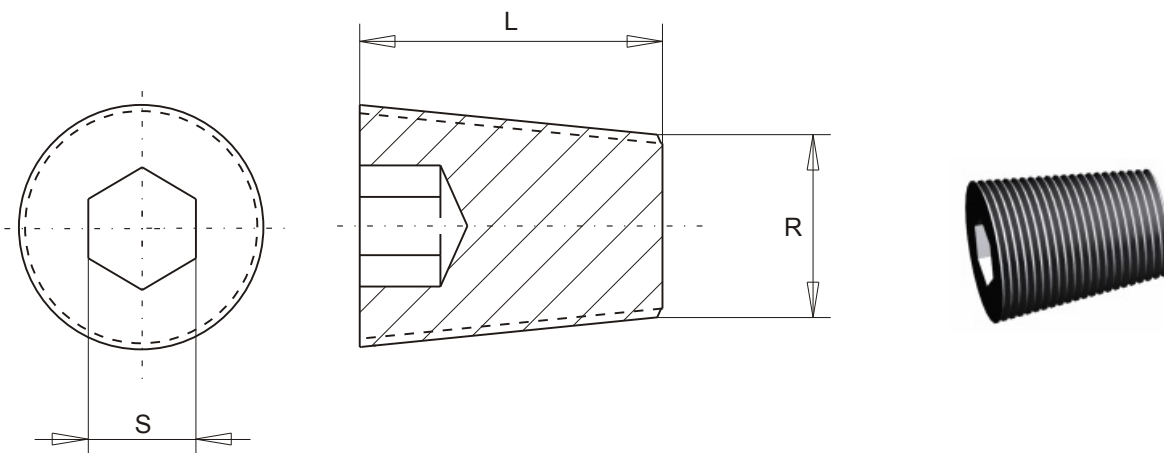
COOLING CIRCUIT SCREW PLUG



MATERIAL: Latón / Brass

R	S	L
1/8"	5	8
1/4"	6	10
3/8"	10	12
1/2"	10	12
3/4"	12	12

FORMA DE PEDIDO / ORDER FORM : R.

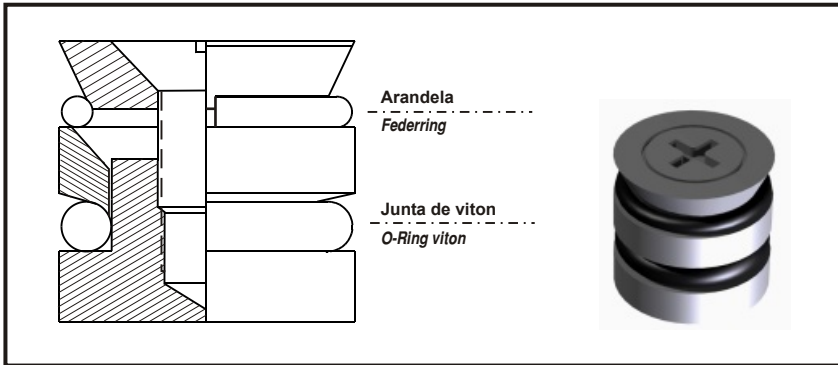
TAPONES PARA CIRCUITO DE REFRIGERACION
COOLING CIRCUIT PLUGS
522

VENTAJAS:

- * Sellan incluso agujeros corroidos u oxidados.
- * No se requiere llave.
- * Pueden ser puestos en cualquier posición.
- * Trabajan con refrigeración o calefacción con agua y aceite.

FEATURE:

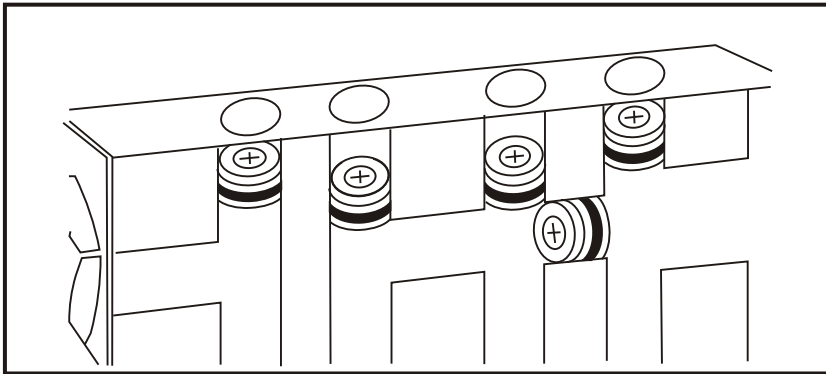
- * Seals even in rough or corroded holes.
- * No tapping required.
- * Can be put on any position.
- * Working either on water or oil cooling and heating.

COMO UTILIZARLO:

- * El alojamiento debe hacerse +0,1 mm mayor que el diámetro del tapón.
- * El tapón puede ser sacado por presión de aire del circuito de refrigeración.

HOW TO PROCESS:

- * The drilling hole should be made by +0,1 mm bigger than plug's diameter. For example, to use plug at $\Phi 8.0$ mm (OD), the drilling hole must be made by $\Phi 8,1$ mm.
- * The plug can be pushed out by air pressing from cooling circuit.

NOTAS:

- * Temperatura normal de trabajo **-5/+135°C**
- * Temperatura máxima de trabajo **-10/+280°C**
- * Materiales: Latón. Acero Inoxidable y Junta Tórica.

NOTE:

- * Normal working temperature **-5/+135°C**
- * Ultimate working temperature **-10/+280°C**
- * Material: Brass, Stainless Steel & O-ring.

PRESION / PRESSURE DATA:

- * $\Phi 8$ mm - 16kg/cm2 up
- * $\Phi 10$ mm - 17kg/cm2 up
- * $\Phi 12$ mm - 19kg/cm2 up

ESPECIFICACIONES / SPECIFICATION

Diametro / Diameter	6mm	8mm	10mm	12mm	14mm	16mm	20mm	23mm	25mm	30mm
Longitud / Length	10mm	10mm	11mm	12mm	12,9mm	14mm	18mm	18mm	19mm	19mm

FORMA DE PEDIDO / ORDER FORM: Diametro / Diameter

SPRUE BUSH "B1/B1T"

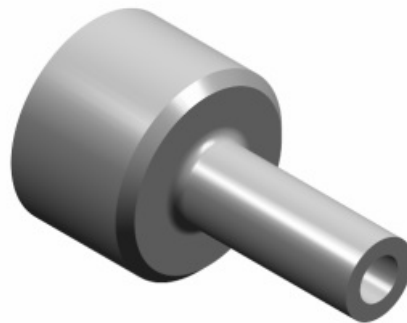
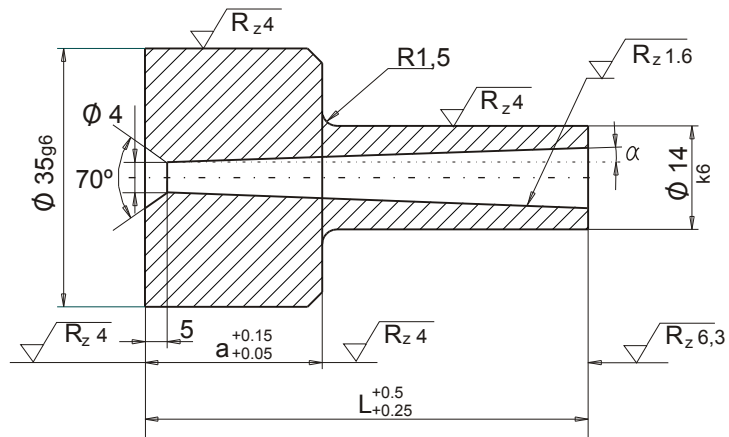

MATERIAL : Acero de cementación / Case hardening steel.

DUREZA : B1 = Sin templar. 21-23 HRc. / Not hardened 21-23 HRc.

B1T = Templado. 60-62 HRc. / Hardened 60-62 HRc.

a	L									d1
	$\alpha = 2^\circ$						$\alpha = 1^\circ$			
	27	36	46	51	60	70	70	100	128	
12	*	*	*	*	*	*	*	*	*	4
24	*	*	*	*	*	*	*	*	*	

FORMA DE PEDIDO / ORDER FORM: B1 o/or B1T / a x L.

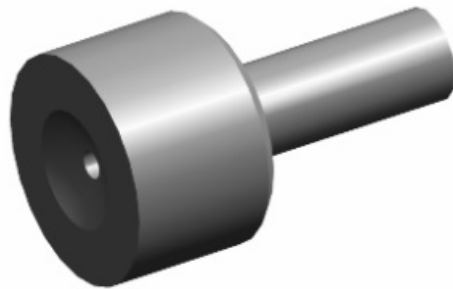
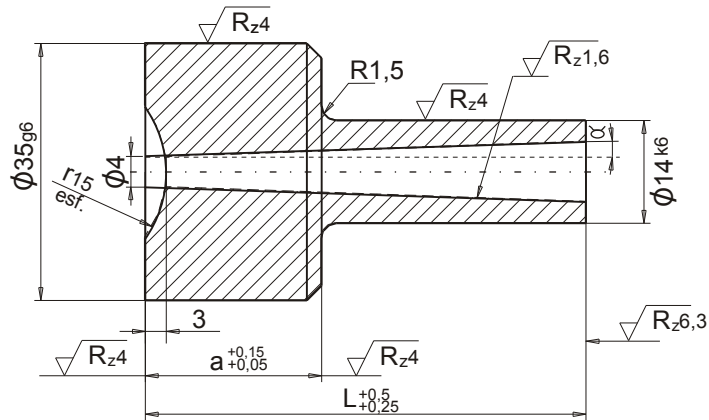
BEBEDERO TALADRADO "B3/B3T"
SPRUE BUSH "B3/B3T"

MATERIAL : Acero de cementación / *Case hardening steel.*

DUREZA : **B3** = Sin templar. 21-23 HRc. / *Not hardened 21-23 HRc.*

B3T = Templado. 60-62 HRc. / *Hardened 60-62 HRc.*

a	L							
	$\alpha = 2^\circ$						$\alpha = 1^\circ$	
	27	36	46	51	60	70	70	100
12	*	*	*				*	*
24				*	*	*		*

FORMA DE PEDIDO / ORDER FORM : **B3** o/or **B3T** / a x L.

SPRUE BUSH "B4/B4T"

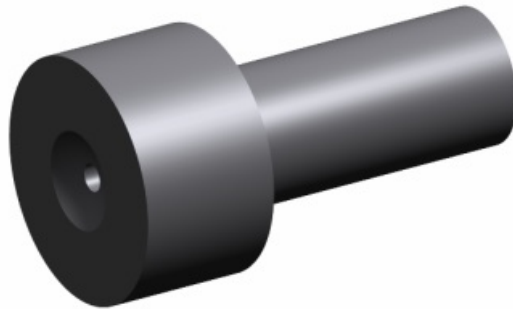
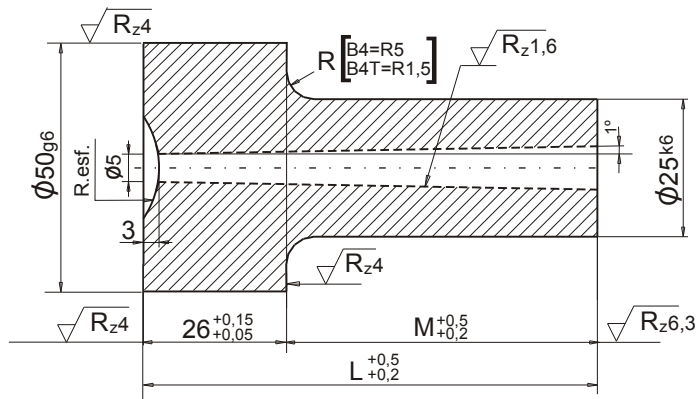

MATERIAL : Acero de cementación / Case hardening steel.

DUREZA / HARDNESS: B4 = Sin templar. 21-23 HRc. / Not hardened 21-23 HRc.

B4T= Templado. 60-62 HRc. / Hardened 60-62 HRc.

M	26.5	36.5	46.5	56.5	66.5	76.5	86.5	96.5	106.5	116.5	126.5	136.5	156.5
L	52.5	62.5	72.5	82.5	92.5	102.5	112.5	122.5	132.5	142.5	152.5	162.5	182.5
R esf.	15, 19 ó 40.												

FORMA DE PEDIDO / ORDER FORM : B4 o/or B4T / L x R.

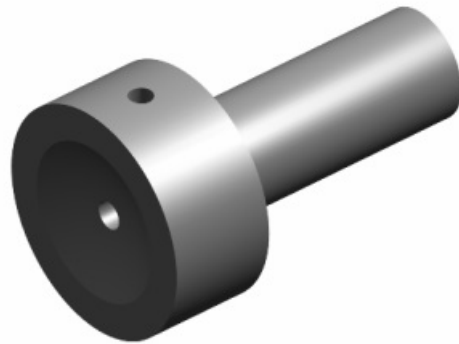
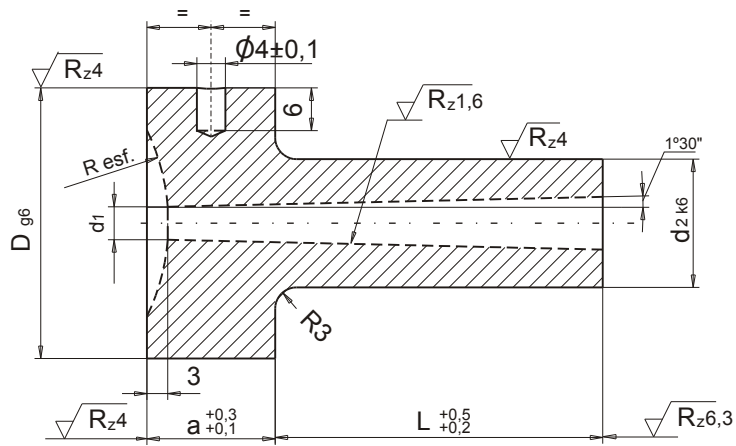

MATERIAL : Acero de cementación / *Case hardening steel.*

DUREZA : 58-60 HRc.

D	a	d2	R esf.	d1	L				
					27	36	46	56	76
38	18	18	15,5-40	3.5	*	*	*	*	
38	18	18	15,5-40	4.5	*	*	*	*	*
48	23	24	15,5-40	4.5			*	*	*
48	23	24	15,5-40	6.5				*	*

FORMA DE PEDIDO / ORDER FORM : D x d1 x L x R.

SPRUE BUSH "B6"

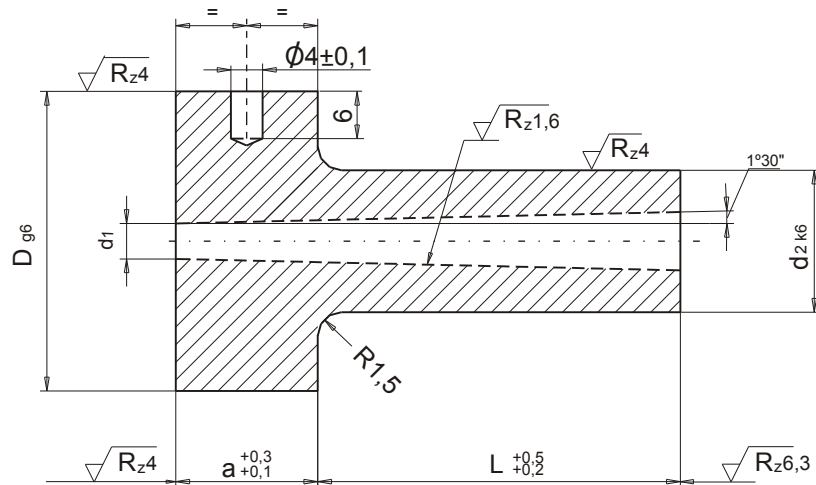

MATERIAL : Acero de cementación / Case hardening steel.

DUREZA / HARDNESS: 58-60 HRc.

D	a	d2	d1	L				
				27	36	46	56	76
38	18	18	3.5	*	*	*	*	
38	18	18	4.5	*	*	*	*	*
48	23	24	4.5			*	*	*
48	23	24	6.5				*	*

FORMA DE PEDIDO / ORDER FORM: D x d1 x L

BEBEDERO TALADRADO "B7"
SPRUE BUSH "B7"

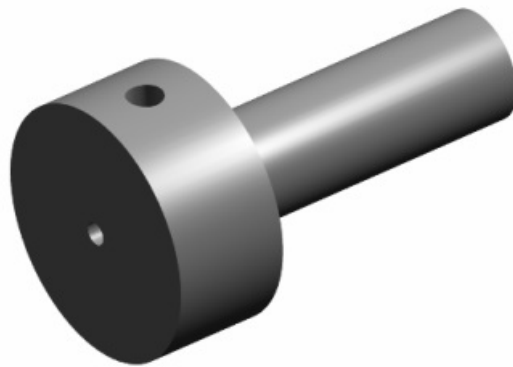
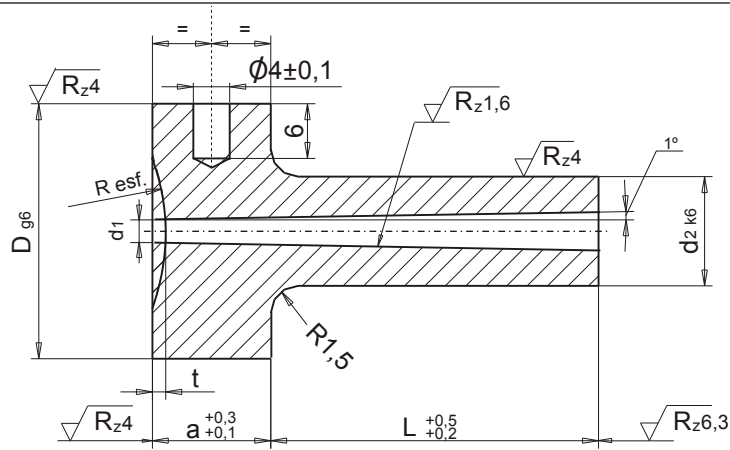

MATERIAL : Acero de cementación / *Case hardening steel.*

DUREZA : 58-60 HRc.

D	a	d2	R esf.	t	d1	L							
						22	27	36	46	56	76	96	116
28	13	12	15,5-40	1.5	2.5	*	*	*	*	*			
28	13	12	15,5-40	1.5	3.5	*	*	*	*	*			
38	18	18	15,5-40	3	3		*	*	*	*	*	*	*
38	18	18	15,5-40	3	4		*	*	*	*	*	*	*

FORMA DE PEDIDO / ORDER FORM : D x d1 x L x R.

SPRUE BUSH "B8"

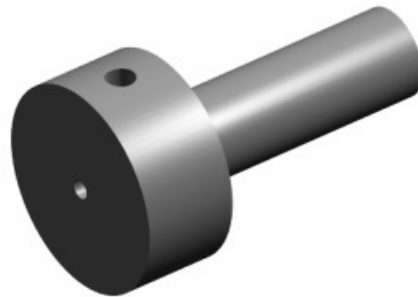
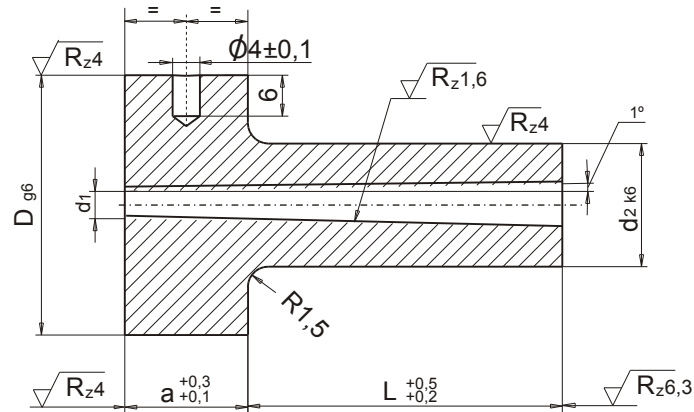

MATERIAL : Acero de cementación / Case hardening steel.

DUREZA / HARDNESS: 58-60 HRc.

D	a	d2	d1	L							
				22	27	36	46	56	76	96	116
28	13	12	2.5	*	*	*	*				
28	13	12	3.5	*	*	*	*	*			
38	18	18	3		*	*	*	*	*	*	*
38	18	18	4		*	*	*	*	*	*	*

FORMA DE PEDIDO / ORDER FORM : D x d1 x L

BEBEDERO TALADRADO "B11/B11T"
SPRUE BUSH "B11/B11T"

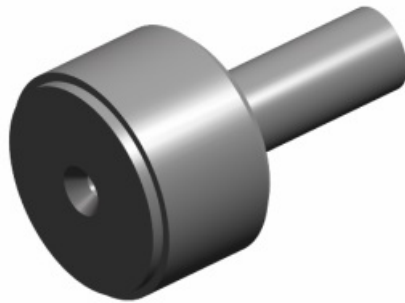
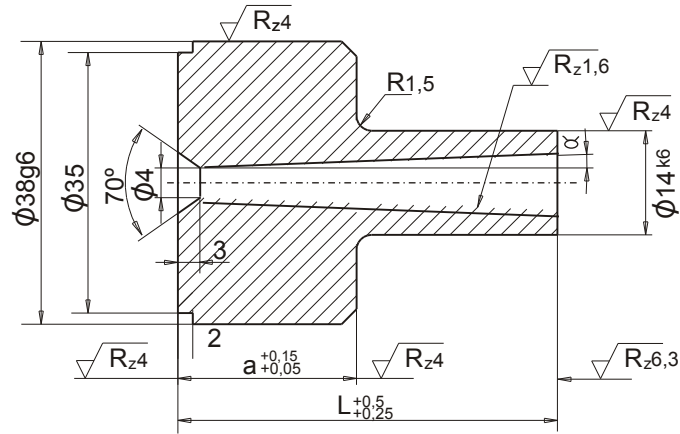

MATERIAL : Acero de cementación / *Case hardening steel.*
DUREZA / HARDNESS: B11 = Sin templar. 21-23 HRc. / *Not hardened 21-23 HRc.*
B11T = Templado. 60-62 HRc. / *Hardened 60-62 HRc.*

a	L							
	α = 2°						α = 1°	
	29	38	48	51	60	70	70	100
12	*	*	*				*	*
24				*	*	*		*

FORMA DE PEDIDO / ORDER FORM : B11 - B11T/ a x L.

SPRUE BUSH " B31 / B31T "

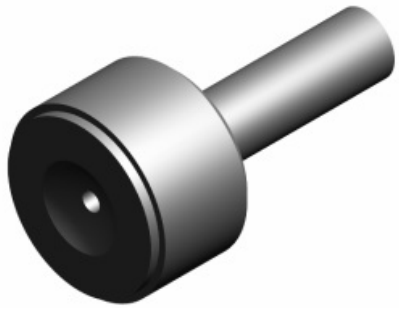
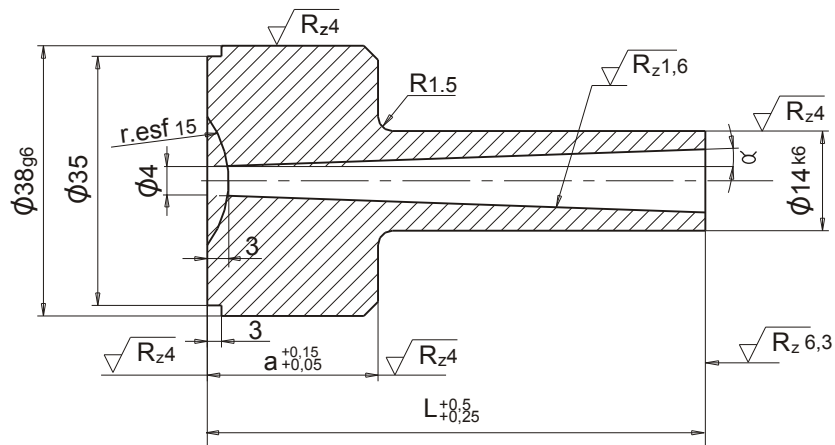

MATERIAL : Acero de cementación / Case hardening steel.

DUREZA / HARDNESS: B31 = Sin templar. 21-23 HRc. / Not hardened 21-23 HRc.

B31T = Templado. 60-62 HRc. / Hardened 60-62 HRc.

a	L							
	α = 2°						α = 1°	
	29	38	48	51	60	70	70	100
12	*	*	*	*	*	*	*	*
24	*	*	*	*	*	*	*	*

FORMA DE PEDIDO / ORDER FORM: B31 - B31T/ a x L.

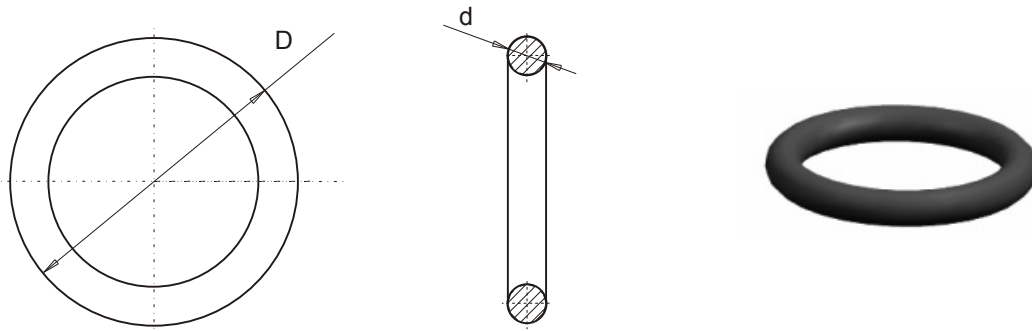

MATERIAL : Caucho sintético o vitón. / *Nitrile rubber or Viton.*

D	d	D	d	D	d	D	d	D	d
6	2	16	1.5	30	3.5	50	5	100	2.5
6	2.5	16	2	30	4	52	2.5	100	6
8	2	17	3	32	3.5	59	3	105	4
10	2.5	18	2	35	3	60	3	120	2.5
10	3	20	2.5	38	3.5	60	4	130	6
12	1.8	20	3	40	3.6	70	3.5	140	6
12	2	20	4	40	4	70	5	150	3
12	3	22	3	43	3.5	80	3	150	4
13	3.5	26	3	45	5	80	4	184	6
14	2	27	3	48	6	85	6	185	3
14	3	30	3	50	3	90	4	210	5

FORMA DE PEDIDO / ORDER FORM : Material, D x d.

SEAL FOR QUICK RELEASE COUPLER

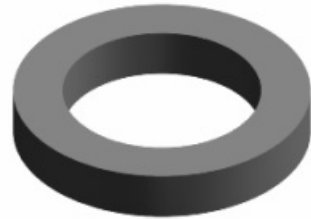
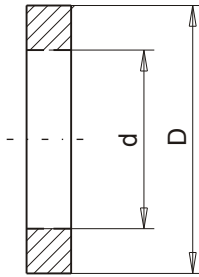
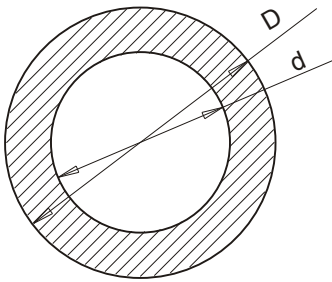

MATERIAL : Silicona. / *Silicone*

d	D
7	10
11	15

FORMA DE PEDIDO / ORDER FORM : d.